



The Redline Times

NEWSLETTER OF THE CAROLINAS CHAPTER, NATIONAL CORVETTE RESTORERS SOCIETY

<http://ncrscarolinaschapter.org>



November 2011

Volume 16 Number 4

ELECTION RESULTS

Chairman	Brian McIntyre
Vice-Chair	Janet Kennedy
Secretary	Carol McIntyre
Treasurer	Louis Kolb
Judg Chr	Duane Ravenberg



Inside this issue...

Vice-Chair's report	2
Membership report	3
Fall judging meet	4-5
Remembering John Pirkle	6
C4 Pwr Stg Fluid Change	7
Judging a Coke can	8-10
Aug. Board minutes	11
Annual business meeting	12
Classified ads	13



Future Chapter Events

Christmas Party Dec. 10
at the Mihaltians'
(see back page)

The Redline Times will be printed bimonthly beginning in January. The next issue will be sent the first week of January.

All material must be in to the editor by December 26.

Fellow Officer Hornaday Remembers John Pirkle

Jim Hornaday, Colonel, U.S. Army, retired

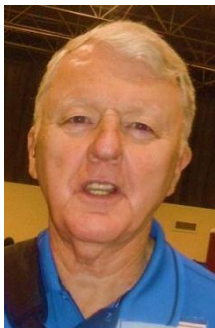

John and his family came into my life while I was still in the military. I was working for a colonel who knew John, and when he found out I was a Corvette fanatic, asked if I knew John and what he did for others that had the same affliction. At the time I had jobs that literally kept me from spending the time I really wanted to engage with Corvettes, but John became my "go-to guy," not just for all things Corvette, but for all things in general, including spiritual advice, and very heavily for advice of a specific nature regarding life as an Army officer.

Our contact was sporadic at first, as I moved around many cities; eventually, I landed back in Huntsville Alabama, where I retired. I knew he was there and I used him as a sounding board for all things, both professional and personal in nature. His advice was sage, direct, sincere, never wavering, and throughout, he always made me believe that he was not only my friend but that the time we spent on the phone or in person was the most important time he had available and he offered that time unequivocally.

When I retired, and began to attend Corvette events, I always spent time with John, Faye and John Jr. and without fail, we always shared a meal at the Sunnyside restaurant in Carlisle. Eventually, our group there grew to about 15 people.

Many people went junking with John to find parts for his customers, but even that became an event when the two of us finally were able to junk together, as we happened to be on 9/11. We had just returned from breakfast to our hotel room to brush our teeth and John said, "They must be making a movie in New York because they just flew a plane into the Trade Center." We had the TV muted, so we turned the volume on, and the second plane hit. In absolute horror, all of our military experience hit home. The very event that we had both served and fought to prevent had come to our shores. It was as if we were back on active duty. We formulated a quick retreat and headed for our respective homes, not knowing if the rest of the country was under attack or was about to be threatened. We actually talked little about that event afterward, but it was the experience that tied two generations of military back to that pride of defense and concern for our country.

We talked regularly, but not frequently, but when we did speak, there was always a connection that I felt and knew he was available if I ever needed him. The Corvette world, of course, knew a different John, but every individual I have ever spoken to about John reflected that same sense that John shot straight, was very passionate about a variety of subjects, and you could depend on him. He was just that simple, and yet totally complex.

Yes, John has left us to go to the next level, but he has touched so many in so many different ways. He is very much still here and will forever occupy the Hornaday household.

Carolinas Chapter Board of Directors

Chair	Brian McIntyre	bamcintyre@charter.net	704.785.4194
Vice-Chair	Janet Kennedy	resalared@prtcnet.com	864.923.4445
Secretary	Carol McIntyre	chipmunk51@charter.net	704.785.4195
Treasurer	Louis Kolb	lkolb@bellsouth.net	803.345.2257
Judging Chair	Duane Ravenberg	dravenberg@triad.rr.com	336.474.1602
Asst. Judg. Chair			
Membership	Sandi Aue	theaues@northstate.net	336.886.2551
Newsletter	Reba Whittington	rebals5@aol.com	336.667.4226
Webmaster	Dick Whittington	dick@whittingtonauction.com	336.469.6967
Regional Director	John Ballard	john.ballard@burgesspigment.com	502.905.3942

The Redline Times is the newsletter of Carolinas Chapter NCRS and is published four times per year—the first week of February, May, August, and November. It is sent electronically to all who have an email address on file and mailed to those chapter members who have no email.

NCRS registered names used in this newsletter are Founders Award,[®] Performance Verification Award,[®] Sportsman Award,[®] Folz Memorial Award,[®] Heritage Award,[®] Master Judge,[®] and Duntov, McLellan, and Hill Mark-of-Excellence Awards.[®] These are registered with the United States Department of Commerce and Trademark Office. Flight Award, Red Hat, and Challenge Car Awards are pending.

Material for the newsletter should be sent to Reba Whittington at the above address. We especially welcome technical articles and human-interest stories about your Corvettes.

Third-Quarter Top Flight Report Completed; Only Two More Items to Do

Janet Kennedy, vice-chair

2011 NCRS Chapter Flight Program

Quarterly Reporting Form

Chapter Name: Carolinas Chapter of the NCRS State: North Carolina

Reporting Quarter 1 2 3 4

Number of members on Jan. 1, 2011: 131

Contact Name: Janet Kennedy Phone #: 864-923-4445 e-mail address: resalared@prtcnet.com

Required Activities

- | | |
|--|--|
| <input checked="" type="checkbox"/> 1. Host one Chapter Judging Meet | Date of event: Saturday, September 17, 2011 |
| <input type="checkbox"/> 2. Conduct one technical seminar. | Date of event: _____ |
| <input checked="" type="checkbox"/> 3. Conduct one judging school. | Date of event: Friday, September 16, 2011 |
| <input type="checkbox"/> 4. Conduct one membership meeting | Date of event: Saturday, September 17, 2011 |
| <input type="checkbox"/> 5. Conduct one stand-alone chapter charitable event. | Date of event: _____ |
| <input type="checkbox"/> 6. Conduct one chapter road tour. | Date of event: _____ |
| <input type="checkbox"/> 7. Conduct one chapter social event | Date of event: _____ |
| <input checked="" type="checkbox"/> 8. Chapter website maintained and linked to www.ncrs.org (need chapter web address by January 1) | |

Address: ncrscarolinaschapter.org

Items 1 through 7 must have supplementary documentation such as sign-in sheets documenting attendance. Each required activity is to be a separate entity.

Variable Activities

1. **7** Number of members to have their car(s) judged at a hosted Chapter/Regional judging meet.
2. **1** Number of technical articles published in the chapter newsletter (send newsletter).
3. **35** Number of members that judged or tabulated at a hosted Chapter/Regional judging meet.
4. **13** Number of members that drove their Corvette to a chapter meeting or event.
5. **__** Number of members that drove their Corvette on a chapter road tour.
6. **31** Number of members that attended at least one chapter event.
7. **__** Set up an NCRS display at a non-NCRS Car event to promote NCRS
8. **__** Amount your Chapter donated to a 501-3C charity. (see new guidelines) (Need a copy of the canceled check or documentation from the charity)

All activities must be conducted according to NCRS Chapter Guidelines.

All items must have supporting documentation (such as sign-in sheets).

2011 Convention Seminars Are Available for Download

The Michigan Chapter has provided links to some of the events held at the Great Lakes National Convention in Novi. Pictures of Corvettes that went to the GM Proving Grounds can be found at www.ncrs.org/2011/index.html



John Hinckley, retired GM plant engineer, presented a seminar on production in the St. Louis Assembly Plant. It was a great presentation on exactly how Corvettes really were built. To access these, go to www.michiganncrs.org Down the right side of the page are seven titles that can be downloaded.

These are Hinckley's presentation in Power Point format:

Corvette Assembly Process (pdf of seminar)
StlBodyPaintShop (ppt)
StlTrim to Engine (ppt)
StlChassisto final (ppt)

Other presentations are available at the Michigan website, including a paint seminar by John Ballard.

Chapter Membership is Now 147; 2012 Dues Payment Approaching

The current membership of the Carolinas Chapter is 147 families. We have been adding new members all year from the monthly report the National gives of new National members who live in our area. A letter with a Membership Application is mailed to them along with any information about upcoming events. We have had a very good response to this.

Chapter dues will be coming due at the end of the calendar year. If your dues expire in 2011, you will be receiving an email or letter along with a membership update form for you to complete and send in with your dues for 2012. This way we can be certain that our records are updated each year.

If your information changes during the calendar year, please email me at theaues@northstate.net or phone 336-886-2551. I am working on a roster for next year that can be saved to your computer. When a member's information changes, you will receive emailed updates.

Sandi Aue
Membership Manager

Convention & Carlisle Reports

John Ballard, Region IV Director

Fall is finally here with reduced temperatures and some rain. October is a full month with the Regional in Sacramento, CA, a chapter meet in Cincinnati and the Southeast Chapter Fall Tour, in Sevierville, TN.

The Novi National is history but a most knowledgeable seminar presentation with numerous photos was presented by John Hinkley. This three-hour-plus presentation, Midyear Corvette assembly process, was in four sections. The first section was a written introduction but the other three sections contained 50-90 photos each—many were not staged. It is a must-see. There are several web sites with the entire presentation (see story at left). Or it can be sent to you. Just email me.

We went to Carlisle for people and parts. The vendors were down about 20% and the people about 30-40%. I had a great time, not the super crowds of people. There were many good parts from people never seen at the event before. Cars for sale were for the most part driver quality or over restored. Several good examples were available for a price.

Any questions or issues please contact me. See you soon at NCRS events.

Regards,
John C. Ballard, Region IV Director
john.ballard@burgesspigment.com

A Real Basket-Case Project Car



--from the Kansas City Chapter's July 2010 newsletter *Classic Corvette News*

Thoughts on the Fall Judging Meet from 1 Vet & 2 Rookies

by Frank Everett, Raleigh, NC

Well, another Fall in the Mountains meet has come and gone. It seems the time we wait for this event just drags but then it's over. This year's meet was darkened by some gloomy skies and an occasional rain drop or two, but that didn't discourage six beautiful cars from showing up. I really enjoy this meet because we seldom get the same cars back for judging. This means we're looking at new candidates for Flight judging each year and we're probably one of the first set of judges to go over them.

One of the best aspects of this meet is that you never know what you'll be judging and who you'll be partnered with. Not to mention the really nice people that bring their Corvettes out for judging. They are the ones that make this event so enjoyable. Generally, you get to share restoration stories with the owner, pass on and get tips about the restoring process and really increase your personal knowledge about the Corvette. The West Jefferson fall meet did not fall short of in any of these categories.

I was fortunate to judge three gorgeous Vettes. Since I generally judge C2s, C3s and C4s, judging a beautiful '54 was a treat. It was a truly great restored specimen from over five decades ago. Fortunately, my judging partner was addicted to these old beauties and knew them inside out. Between him and the '54, I couldn't have asked for a better experience. I can't forget to mention the 1962 and 1966 cars. Both were really nice and a pleasure to judge.

As usual, the meet was very well attended by chapter members. The Carolinas Chapter Women's Auxiliary was on hand raising money for the Wounded Warrior Project and helping out with various tasks. One of the many highlights for them was the lunch--hot soup, fresh sandwiches and desserts. Wow, those desserts. If you didn't get a sugar rush, you just don't know what you were missing. Thanks, ladies, for taking care of us!!!

Once again, this year's Fall in The Mountains was a great event and I'm sure we're counting the days until next year's.

from Robert Merlin, Summerfield, NC

Let me just say I love Corvettes, and I have for my entire life. I have an entire library of Corvette books. I thought I was very knowledgeable about the car. That is until I went to the West Jefferson, NC, for the Carolinas Chapter judging event. I had just spent three years and countless dollars restoring my early 1984 (first year C4). Driving up to the event, I got to see my odometer hit 50,000. I knew I had made some modifications which would take off some points (wood dash, Bluetooth, CD player) but everyone told me I should still get enough points to get the coveted Top Flight.



I had already joined the National NCRS and the Carolinas Chapter. I felt I should support the local chapter; after all, they were taking the time to judge the cars. I had purchased the books I needed from the NCRS and read them, so I thought I was ready. I knew there was a problem when I became as nervous as a cat on a hot tin roof the night before the event. By the time I arrived at the hotel I was a basket case. Yes, this was my first time being NCRS-rated. I have entered car shows but this was no comparison.

The next day the judging started and I was up early for the event. It began to rain and stayed like that for hours so things slowed down some. Five hours later they called me to start my car to begin the process. Four hours after that the judging was over. I thought about what had transpired while holding my hand wrapped in ice after the spare tire dropped on it. (The tire had never been taken down) A few thoughts came to my head; I learned more about my car than I ever knew. All the judges were very respectful of me and my corvette. I always felt they were trying to help me even when the points were adding up. I found myself calming down during the process because I felt I was among friends who understood what I was going through. I decided I wanted to learn more about becoming a judge and giving back to other Corvette owners.

I would encourage any owner to respect his/her car enough to get it NCRS-rated. It was worth the anxiety and I made some new friends in the process. Even my wife, who was going for my benefit, said she really enjoyed the weekend and the judging. Oh, I did get Top Flight and it is in a shadow box next to Rick, my Corvette.

RESULTS FROM FALL CHAPTER MEET, WEST JEFFERSON NC

Flight / Sportsman Awards

Flight

Tommy Loftin	1954	Top Flight	Troutman NC
Ray Culbertson	1962	Second Flight	Greenwood SC
Chris Allison	1966	Second Flight	Indian Spring AL
Carlton Tyson	1968	Top Flight	Monroe NC
Rick Conway	1969	Third Flight	Pelham AL
Robert Merlin	1984	Top Flight	Summerfield NC



Road tour members on Blue Ridge Parkway

Sportsman

Fred Baritell	Raleigh NC
Frank Everitt	Wake Forest
Valeria Hutchinson	Charlotte NC
Harold Kennedy	Gray Court SC
Brian McIntyre	Denver NC
Lionel Putnam	Marion NC
Wes Schrom	Raleigh NC



photos by Carla Mood

A Little Red 1962 Shares Its Story with Us

submitted by Rick and Barbara Gandy

If you have just a minute, I'd like to tell you my story. You see, I'm a 1962 Corvette. Back In 1988 I was purchased by Chuck and Susie Gandy and moved to their home in West Virginia. I was in pretty rough shape at the time, but they both knew my potential and started slowly bringing me back to life. Chuck's brother Rick often came around to help out. My rebuild went slowly at first until the day Rick's daughter was nominated for homecoming queen and announced she needed a car for the parade. I was quickly designated for that privilege, but there was a lot of work to be done to get me ready for the big day.



Everyone worked together and after some long nights and a few arguments, I was finished just in time to carry the new homecoming queen. After that, I had to take a back seat while Chuck was building his new house. I watched the activity each day thinking his attention would come back to me whenever it was finished. But that never happened because Chuck ended up getting very sick, so sick that he passed away. After that, I was moved to a lonely storage facility where I was pretty much forgotten. Eventually, I ended up being moved outside on a city street where kids sat on my fenders throughout the day watching the cars go by.

I was truly in a sad condition from all those years of neglect, but you couldn't tell it by watching Rick and Barb. They started right away getting everything together to start my restoration. At first, I just knew I'd met my doom because Rick took me completely apart—every nut, bolt and screw. But when he started putting me back together with such great care, I realized that something was different. I saw that to Rick I was more than just any car. I am the car that he and his brother Chuck worked on together, the car that carried his daughter when she was crowned homecoming queen all those years ago and now the car that he rebuilt from top to bottom with his own hands.

Nine years to the day after Chuck passed away, Susie came to visit and was very saddened by my condition. She remembered that Rick had promised to give me a home should she ever decide to let me go. The very next day Rick and his wife Barb drove up my street with a big trailer, loaded me up and took me to their home. Imagine my delight when I realized my new home was right next to where I had lived with Chuck. It seemed the whole family was glad to see me again.

So now that I'm just like new again, sitting before you today in all my glory, I wanted you to realize that I am one of the luckiest of cars. That's because I'm loved not only for being a 1962 Corvette but also for the memories I carry to the family that owns me.

The Gandys are relatively new members of the Carolinas Chapter. This car was first judged at the West Jefferson fall meet in 2010. It has since earned a Top Flight at the New Jersey Regional in May 2011.

We Lose a Great Friend and Gentleman in John Pirkle, Sr.

The Corvette hobby, as well as this country, lost a great American gentleman and loyal friend when John Pirkle, Sr. passed away September 30 in Augusta, GA. If John had an enemy in this world, we never met him. His honesty and integrity was never questioned in anything he did—be it his country, his church, or his friends in this car hobby.

He co-chaired the 2000 National Corvette Museum Convention in Bowling Green, chaired the 2010 Speedway National in Charlotte, and served as the NCRS representative on the Museum board for 10 years. He owned Masters City Parts, which sells and restores alternators, starters, horn relays among other parts. He was a member of the Carolinas Chapter and attended many chapter and regional events. The chapter extends deepest sympathy to his wife Faye, daughter Myra and son John, Jr., who is also a chapter member, and the grandchildren.

Here are some comments from Carolinas members. . . .

I knew John briefly. His knowledge of parts and the detail within were unsurpassed, and he would share that knowledge freely whether you bought from him or not. A true gentleman.
--George Fortunes

Mr. Pirkle was a true gentleman's gentleman and I was blessed to call him a friend.
--Ken Chapman

John was a true gentleman and a true friend that loved his country and his friends I will miss him.
--Mike Cranford



John always had time for anyone and everyone, and I am proud to say I knew him.
-- Jeff Burkey

John was truly one of the finest people I've ever met. We have lost a great man.
--Frank Everitt

Godspeed, Colonel, human beings like you are a blessing to us all. See you on other side... hopefully, you will have the aviation department running smoothly by the time I get there.
--Mark Donnally

I came to know John through a mutual friend C.H. Nolley Jr., who like John passed away much too early. John offered encouragement and guidance in the restoration of my 1966 Corvette. I will always remember John as the consummate gentleman and a truly great American.
-- Gene Bowman

John and Faye are some of our longest NCRS friends. We will forever treasure the week we spent at the same hotel in Novi enjoying several meals with them. We will miss John but know that God has a place for him.
--Dick & Reba Whittington

Thank you, John Pirkle, for your support of our hobby and being a true Corvette enthusiast and friend.
---Bill Locke

There have been many things written describing the wonderful man John Pirkle, Sr. was. To me, there are no words adequate or eloquent enough to truly portray the man he was. Of all the words that come to mind, John was, foremost a noble man in every sense of the word and in every aspect of his life.

He practiced every word he preached. He believed in his Lord and Savior and continually witnessed his beliefs to any and everyone that would listen. He was a great story teller and would often share his experiences of his many mission trips he took with his church and of the people he led to Christ along the way especially, his dear sweet Claire.

John has left behind an extraordinary legacy for his wife Faye and immediate family, his extended family, community and his NCRS family.

*I am forever thankful, proud and privileged to have known John and to have been a part of his life. I will miss John but know I will be seeing him again!
Until then, rest in peace, John!*

---Janet Kennedy

C4 Power-Steering Fluid Change

by Peter Mihaltian #47240

The Corvette C4 power-steering system fluid should be flushed and replaced with new fluid every two years or 12,000 miles, whichever comes first. C4 rack & pinion systems can develop fluid leaks, as well as suffer from the dreaded *morning sickness*, if the fluid is not changed on a regular schedule.

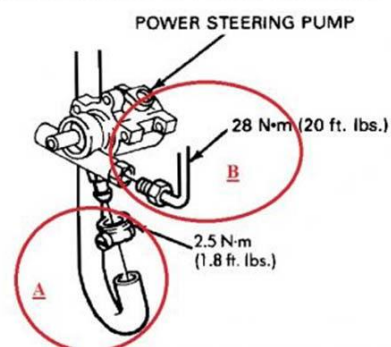
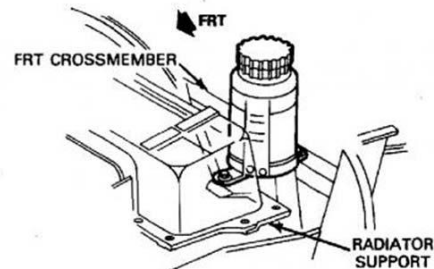
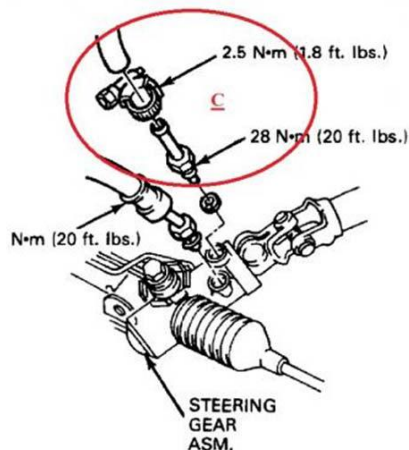

The power-steering system flows from the reservoir to pump to rack and back to reservoir. You can flush the system by intercepting the return fluid before it gets back to the reservoir. The *A line* in the above diagram is the suction line to the power steering pump and runs to the bottom of the reservoir. Accordingly, the *A line* feeds the pump. The *B line* is the pressure line that flows fluid to the rack & pinion. The *C line* is the return line from the rack & pinion to the power steering pump. The *D line* is the return line to the reservoir.



To flush the system, you have to go through the pump and recover the fluid before it gets back to the reservoir. To accomplish this, disconnect the *D line* that is about halfway up on the reservoir and find a way to catch the fluid that comes out of the line. To flush the system properly, you also have to turn the steering wheel lock-to-lock because the rack is full of fluid too...and the rack is where most of the dirt and debris is located.

The flushing process really is more complicated than it seems. Most folks are satisfied with sucking the old fluid out of the reservoir, running the engine and turning the wheels followed by sucking the fluid out again. Generally, that process will get the majority of the old fluid out. However, it will take about a gallon of new power steering fluid to completely flush the system. You can also add

some power steering rack & pinion conditioner to prevent the dreaded *morning sickness* that is so common on C4 rack & pinion systems.

You will have to have a second person assist either by adding fresh fluid to the reservoir as it gets used or by turning the pump. It is helpful to rig a hose to a plastic container to collect the old fluid.

Follow these steps to complete a thorough flushing of the Corvette power rack & pinion system:

1. Disconnect the power + line to the distributor. This will allow you to crank the engine and the power steering pump using the starter without actually starting the engine.
2. Disconnect the *D line* at the PS reservoir, Use a pan or large plastic container to catch the fluid which comes from the pump via the *D line*.
3. Crank the engine while turning the steering wheel slowly lock-to-lock.
4. While the engine is being cranked, add fresh power steering fluid to the reservoir being careful to assure that the reservoir *never* runs dry.
5. Continue to crank the engine, add new fluid and turn the steering wheel from lock-to-lock until the fluid coming out of the *D line* runs clear.
6. **WARNING!** The Corvette power-steering pump moves fluid *REAL* fast. Accordingly, this process can get *REAL* messy if you are not properly prepared.

Can You Actually Judge a Coke Can?

Duane Ravenberg #17685
and Bill Sangrey #5437

The answer is definitely yes! In March of this year, both the Carolinas Chapter and the Mid-Atlantic Chapter held judging schools independent of each other. However, the topic of Coke Can Judging was a joint effort by the authors of this article.

What led to this was that Bill Sangrey and I had been talking for some time about the possibility of applying Roy Sinor's words from Regional judging schools: "If you apply the NCRS judging process, you can judge a Coke can." Having heard this so many times, it had been in the back of our minds for quite a while. We were kicking around ideas for possible tech sessions one day and arrived at the idea to practice what Roy has been preaching: have a judging school on how to judge Coke cans.

You might ask, "Why? How? To what purpose?" Well, here's more of the story. As Bill's high school English teacher said so often, "If you'll willingly suspend any feelings of disbelief..." you can envision some pretty good things. With that attitude in mind we developed the following scenario for the Coke can judging school to be presented to both chapters.

The Scenario and the Rules

- NCRS is now judging 2010 C6 Corvettes.
- As a promotional deal in the spring of 2010, GM installed an unopened 12-ounce can of standard-production Coca-Cola in the cup holder of each 2010 Corvette built at the Bowling Green Assembly Plant as shown in this reference can photo.
- The production date for the car was Friday, April 23, 2010.
- Assume the date on the cans is the production date and not the expiration date as normally is listed for beverages.
- Each can has a part number.
- Each can is a single-line item on the judging sheet with Originality assigned 25 points and Condition 20 points. A total of 5 pts. is assigned for cleanliness of the can.
- Originality is to be judged as to its Completeness, Date, Configuration, Installation, and Finish. Judges must determine the point value assignments across the CDCIF matrix.
- Keep the 10% originality rule in mind: To receive any Condition points, the can must receive at least 10% of its originality points. (In this case, originality deduction cannot exceed 22 pts. to receive Condition pts.) Items missing on a can may not receive the corresponding condition points.
- It is okay for judges to handle the can; however, they must replace the cans in their original positions in the simulated cup holders for the next team of judges.

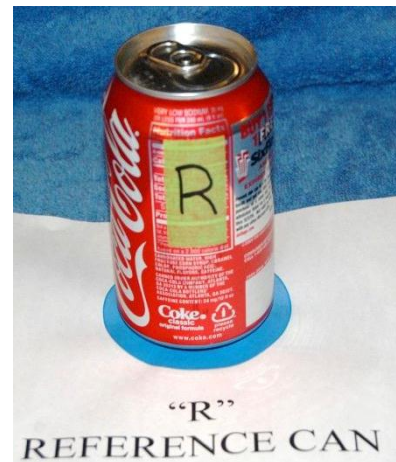

Take a look at the following photos of the ten cans used in both judging schools and evaluate each one, deciding how you would judge it. Assume that all cans were installed in the can holders. Then look at the Practical Exercise Point Deduction list and scoring summary to see how you fared. Deductions for each can are explained as to how they deviated from typical of production, condition and cleanliness. Once you've read through this and attended a Coke can judging school, you'll be qualified to Judge Coke cans on your own.

Continued on next page »

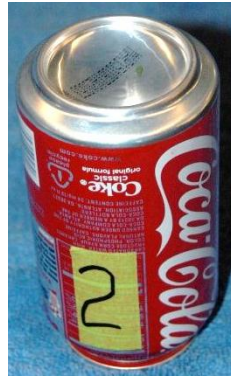

Can 1 Typical of production full credit on originality
Deduction for cleanliness mud on top

Can 2 Configuration tab is turned down; cannot be pulled to open
Installation can installed upside down

Can 3 Date date is missing
Condition much of finish is worn off

Can 4 Configuration spout cover is bent downward
Completeness can is empty; tab is missing
Condition deduction must be taken for missing tab

Can 5 Completeness can is empty
Configuration spout cover bent down
Installation cannot be properly installed due to shape
Condition can is crushed

Can 6 Date Jan. 24, 2011 (later than car)
Condition dented

Can 7 Configuration "Celebration" graphics NTP.
Date Could be COPO, but there is no documentation.
Feb. 28, 2011 (later than the car)

Can 8 Completeness can is empty
Condition can has pin holes

Can 9 Configuration not TFP; can is 7½-oz. Diet Coke
Finish incorrect color
Date Apr. 4, 2011

Can 10 Full deduction Milwaukee's Best is not OEM; Coca-Cola has never made beer.
(Even for the hardened beer drinker this is still a full deduction.)



Continued on next page »

Coke Can Judging Sheet

Originality 25 pts.

Can	Configuration	Date	Completeness	Installation	Finish	Condition (20 pts.)	Cleanliness (5 pts.)
1							3
2	5			5			
3		5				5	
4	5		5			5	
5	5			5		5	
6		5				5	
7	5	5			5		
8			5			5	
9	5	5			5		
10	5	5	5	5	5	20	

Note: Point values indicated and areas of deduction are for illustration only; scores of individual judges may vary.

Seriously, this is a good teaching tool as evidenced by the positive comments received at both the Carolinas and Mid-Atlantic judging schools. The session allows judges to focus on the NCRS Judging Standard (paraphrased) as *manufactured, subject to standard dealer prep* without “falling in love” with a particular car. When reviewing the individual team results at the end, much discussion took place regarding the points assigned to deduction and in which element of CDCIF they were made.

Participants learn to apply the principles of CDCIF while learning to differentiate between originality and condition. They become familiar with the process of point-value distribution across the CDCIF elements while learning how to be consistent from can to can. The sessions also focus on the meaning of *not typical of production* (NTP). Besides, it is a fun, learning exercise without the pressure of learning under fire at an actual judging meet.

***The Redline Times* has grown and grown and grown**

Reba Whittington, editor

With apologies to the old slogan about women's equality: “We’ve come a long way, baby.” When I assumed the job of newsletter editor last fall, my biggest worry was not having material to fill each issue, a problem I had encountered with other groups. Well, you chapter members have put that to rest. I planned a layout of eight pages for each issue, and the first one contained exactly that. But that didn’t last long; February had 12 pages; May, 10; and August, 14, and this one will equal that.

Technical articles have been the most pleasant surprise. There has been one in each issue and two in some. We have had lots of photographs, which everyone seems to like. Many thanks go to everyone who sends pictures. Readers also enjoy human interest stories about you and your cars, like the one from the Gandys on page 5. Tell how you found that Corvette or an interesting

experience you have had (not like some of mine), or a road trip taken in the car. I know one family that brought a baby home from the hospital in their 1969 and then used the same car in her wedding.

Fifty years ago, I entered college to major in journalism, but took a different route. The closest I got was overseeing the school newspaper. I am thoroughly enjoying the challenges of editing *The Redline Times*. With the completion of this edition, I will have sent copies of all 2011 issues to the judging team for the Golden Quill Award. They will announce decisions sometime around March or April. Thanks to you members, this is a Top Flight publication. We are increasing to six issues next year, so I will need even more material from you. Keep it coming; we’ve only just begun.

2012 NCRS Regionals and Convention

January 25 -28 Kissimmee FL

March 8-10 Tucson AZ

May 3-5 Seaside OR

June 7-9 Rochester MN

June 30- July 4

NATIONAL CONVENTION

San Diego CA

September 6-9

Altoona PA

October 18-20

Frisco TX

CC BOARD OF DIRECTORS MEETING
August 21, 2011

Date: August 21, 2011

**Location: Ravenbergs, 258 Running Stream Lane,
Thomasville, NC 27360**

Brian McIntyre, chairperson, called meeting to order.

Present at the meeting:

Brian McIntyre	Carol McIntyre	Sandi Aue
Janet Kennedy	Louis Kolb	Jane
Ravenberg		
Duane Ravenberg	Reba Whittington	Dick
Whittington		

MINUTES OF THE LAST BOARD MEETING

The minutes from the July 18, 2011, board meeting were accepted by acclamation.

TREASURER REPORT – Louis Kolb
No report for this meeting.

MEMBERSHIP REPORT – SANDI AUE
We currently have 142 members.

TOP FLIGHT CHAPTER REPORT – JANET KENNEDY
We are looking good for achieving Top Flight. The only remaining requirements to be fulfilled are the donation to a charity requirement and the annual meeting.

CAROLINAS WOMEN'S AUXILIARY (CWA) – JANE RAVENBERG
Total monetary contributions have not changed since our last meeting.

Janet brought a carload of items for donation to the Family and Morale, Welfare and Recreation Program (FMWR).

Jane reported that it is not doable for the CWA to volunteer for FMWR fund-raising events as a group. The program is more interested in cash donations.

The CWA is also discussing the possibility of planning a women's weekend getaway,

NEWSLETTER – REBA WHITTINGTON

There was nothing new to report. The chapter has already fulfilled the minimum number of technical articles required for Top Flight, but Reba is still receiving more from members. She is still waiting for the Golden Quill submission procedures.

OLD BUSINESS

BYLAWS UPDATE – BRIAN MCINTYRE

The board reviewed the bylaws revisions. Reba and Carol will prepare the final draft. The board will meet to review the final draft before it is sent out to members.

FALL MEET – SEPTEMBER 16-17 IN W JEFFERSON

Carol reported registration totals as of Friday, August 21:

Registrations:	24	Sportsman:	8
Flight Cars:	6	Judges:	16
Tabulators:	2		

Carol will draft a registration reminder for Sandi to email out to the members. The deadline for getting a block room at the hotel has passed. 14 of the 20 blocked rooms are booked.

Friday Dinner - Since we all usually eat at *Frasers Restaurant and Pub*, Reba will reserve the back room for our group.

Saturday Lunch – Janet will order sandwiches from Subway for all registered participants.

Saturday Dinner & Annual Meeting – Brian will reserve the private dining room at Smokey Mountain Barbeque.

Drinks - The Whittingtons volunteered to bring canned drinks, ice, their big cooler, wash tub and water cooler.

Judging School – Possible topics were discussed. Brian will reserve a room.

Standard Deduction Guidelines; Revision 8 – Dick & Reba will prepare copies for distribution at the Judges' Meeting.

Tables & Tents - Brian will ask Chip Drennan to bring 2 tables and 2 tents that he stores for our chapter.

CWA Yard Sale – Janet will bring items left over from the 2010 convention. Brian also has some items. All donations for yard sale are welcome.

Picnic – October 8, 2011

North Carolina Transportation Museum in Spencer, NC – We will tour the museum in the morning then proceed to the picnic.

Dan Nicholas Park in Salisbury, NC - Duane reserved a pavilion with its own private parking lot. Pavilion is equipped with picnic tables and grills.

- Club will provide drinks, burgers, hot dogs, buns, condiments, plates & utensils.
- Whittingtons will pick up the drinks (no alcohol permitted).
- Attendees should bring a dish to share.
- Duane will draft a flyer and send it to the board for review.

Assistant Judging Chairperson

Gary Jaynes is not able to fill this position. It will left open for now.

Election of officers in September

So far, Dick is a nominating committee of one. Several possible nominees were discussed. Sandi will send out an email asking that nominations be sent to Dick.

Hendrick Liaison position Currently on hold.

Charitable contribution and matching funds

Brian has the correct information and will submit the application.

Christmas Party

The Christmas party was changed from Dec.10 to Dec. 3 due to a conflict with the Southeast Chapter's party. Brian will follow up with arranging a location

NEW BUSINESS

Annual Meeting will be on Saturday evening, September 17, 2011, at Smokey Mountain Barbeque. It will include the usual business, election of officers and a report on the status of the bylaws revision.

Potential 2012 Recruitment Venue Possibilities

Carolina Collector Auto Fest, Raleigh March 9-12
Charlotte Corvette Bash, Charlotte, March 30-31

NEXT MEETING DATE/LOCATION

The next board meeting will be at the Hampton Inn, West Jefferson, on September 16, 2011, at noon. The purpose of this meeting is for a final board review of the revised bylaws. Board members should bring a lunch.

No further business was conducted and the meeting was adjourned.

Carol McIntyre, Secretary, NCRS Carolinas Chapter

CC ANNUAL BUSINESS MEETING
September 17, 2011

Location: Smokey Mountain Barbecue, West Jefferson, NC

Brian McIntyre, Chapter Chairperson, called the meeting to order.

Awards Presentation:

Duane Ravenberg, Judging Chairperson

Sportsman

Fred Baritell

Frank Everett

Valeria Hutchinson

Harold Kennedy

Brian McIntyre

Lionel Putnam

Wes Schrom

Flight

Tommy Loftin 1954 Top

Ray Culbertson 1962 Second

Chris Allison 1966 Second

Carlton Tyson 1968 Top

Rick Conway 1969 Third

Robert Merlin 1984 Top

OLD BUSINESS

Last Year's Minutes

Jimmy Gregg made a motion, seconded by Dick Whittington, to adopt the minutes of last year's meeting as printed in a past newsletter. Motion carried.

Chairman's Report

Brian reported on this year's chapter events which included:

November 2010 – judging school at Dick Bridges'

December 2010 – Christmas party at Pete & Mary Mihaltian's

February 2011 – judging meet at Wes Schrom's

March 2011 - judging school at Harold & Janet Kennedy's

April 2011 – judging meet at Mororama

April 2011 – judging meet at Hendrick Motorsports (we want to continue to build on that relationship)

June 2011 – A Day At Old Salem

September 2011 – judging meet & judging school in West Jefferson

Membership Report – Sandi Aue

We started the year with 119 memberships. Through Sandi's efforts, our chapter gained 25 new memberships, for a total of 144 memberships. All members now have chapter name badges.

Top Flight Chapter – Janet Kennedy

Janet reviewed the Top Flight Chapter requirements. Our chapter has completed all but one requirement – sending the charity donation checks. We should achieve Chapter Top Flight for this year. Top Flight awards for 2011 will be presented at the 2012 NCRS National Convention in San Diego.

Carolinas Women's Auxiliary (CWA) – Jane Ravenberg
Jane gave a brief history of the Carolinas Women's Auxiliary (CWA) of the Carolinas Chapter of the NCRS. The auxiliary was founded in January 2011 to provide a venue for women of the chapter to be involved. The CWA is dedicated to the charitable endeavors of the Carolinas Chapter. Its founding members and first slate of officers are Jane Ravenberg (President), Sandi Aue (Vice President), Janet Kennedy (Secretary) & Carol McIntyre (Treasurer).

This year's fund raisers – which included a donation jar and 50/50 drawings at most chapter events plus a yard sale – raised a total of \$1,150.50. All proceeds will be donated to the Wounded Warrior Project. In addition, Jane and Sandi delivered to Fort Bragg a truck load of donated items for military families and they have another truck load ready.

There are tentative plans for the CWA to spend a social day at this year's Charlotte Christmas Show.

Newsletter – Reba Whittington

Last fall we held a chapter-wide name-the-newsletter contest. David Mizell's entry, *The Redline Times*, was the winner. This year Reba has updated the newsletter and increased the content. She also switched to electronic distribution which is saving the chapter approximately \$1000/year in supplies and postage. Beginning in January, the newsletter will be issued bi-monthly.

Reba entered *The Redline Times* in the Golden Quill Awards competition. She's already sent in the first three 2011 editions. She just needs to send in the final 2011 edition.

Treasurer's Report – Louis Kolb

The beginning balance (as of January 1, 2011) was \$6,931.54. The balance (as of September 14, 2011) is \$10,211.89. A portion of the current balance is earmarked for donation and we still have some expenses to cover. A copy of the itemized financial report is attached to these minutes.

OLD BUSINESS

Bylaws Update – Brian McIntyre

An ad hoc committee lead by Wes Schrom, and including Frank Everitt, Dave Gregorino, Wayne Jackson and Gary Jaynes, drafted a revision of our chapter bylaws. The final draft will be distributed to all chapter members (via email) no later than this Wednesday, September 21, 2011. Reba will mail a copy to each member who does not have email. We will hold a special meeting at the picnic on October 8, 2011 for the express purpose of voting on the bylaws.

NEW BUSINESS

Election of Officers – Dick Whittington

Nominations chair Dick Whittington handled the nominations and election of officers for the coming year. The following officers were accepted by acclamation:

Chairperson – Brian McIntyre

Vice-Chairperson – Janet Kennedy

Secretary – Carol McIntyre

Treasurer – Louis Kolb

Judging Chairperson – Duane Ravenberg

(Since Carol McIntyre expressed a desire to step down as Secretary, Dick called for nominations for Secretary. However, no one was willing to be nominated.)

Upcoming Events

Picnic – October 8, 2011, Duane Ravenberg

Duane reviewed the picnic plans. We will begin the day with a tour of the North Carolina Transportation Museum in Spencer, NC, then proceed to Dan Nicholas Park in Salisbury, NC, for a picnic. So far, there has not been much response to the flyer and registration form sent out earlier this month. Duane encouraged all to sign up.

Christmas Party – December 10, 2011

Once again, Pete and Mary Mihaltian offered to host the chapter Christmas party at their home.

SE Chapter Fall Court Tour – October 14-15, 2011 in Sevierville, TN. They are always looking for judges.

Continued on next page →

Carolinas Classifieds

Chapter members may run one free ad in each issue equal size to a business card. Commercial rates are \$10 for one-quarter page, \$20 half page, and \$30 full page.

Ads will not be carried over, but must be re-submitted for each issue. Between issues, classifieds will not be disseminated by special email to the membership.

FOR SALE

Set of 4 recently refurbished magnesium wheels with new tire pressure sensors from 1999 C5, \$1,500. Jeff Burkey #31259 at 704.892.6007, or jmburkey2@mi-connection.com

Corvette News collection, complete from Vol.1, No.1, through the last issue of *Corvette Quarterly*, in binders and slip cases. *Corvette: The Sensuous American* by Michael Antonick, all volumes. Bill Locke #76 716-386-2107, 704-948-8107 or after Nov 22, wrlenzo@aol.com

1974 original spare Goodyear Steelguard raised white-letter tire & wheel, never on road, \$300. 1974 complete original ignition & spark plug shielding \$350. Four 1980-1982 replacement wheels, like new \$500. Tom Lombardo #22194 704-845-0947 home, 978-423-8567 cell

1984-91 Corvette right front spoiler, deep Z51 version, fits 1985 2nd design, 1986 all, and 1987-90 with Z51 performance handling option.
\$14 shipped within US



Absolute Auction
100+ Salvage Corvettes
All stored in dry warehouse

Saturday, November 5, 2011 at 10:00 AM



610 Old Caroleen Rd
Forest City, NC 28043

Dick Whittington. CAI, MPPA NCAL 8424
Whittington Auction & Appraisal Llc

336-838-8243 Details at whittingtonauction.com

See ad on next page also

NOS big block and small block intake gasket sets w/GM logo; radiator caps RC-15, 307, 558-9 (RC-7); RB12 Trico wiper refills w/ dots \$40 pr; wiper blades—all years and styles; C2 off-road NOS exhaust system; 1965 radio with speaker; 1954 dated shocks, 1963 early "notched" hardtop \$1000; 1961 Corvette voltage regulator dated late 1960. Much more--mostly C1 and C2. Jim Gregg #2756 tio2jim@aol.com or 704.577.9812 on weekends.

1968-75 soft top frame: All hardware is on the frame and is good driver quality, has been sand blasted and repainted, ready to mount in car \$1000. 1968-82 tire tub complete with lid, front and rear bolts and bracket, lock and key \$250; tilt-tele black steering column that will work in 1968-82 \$600. 828-632-2172 Don Austin #41818

1) 1965 Nassau Bl cpe, blk int, 327/365, 4-sp., 4:11, side pipes, teak tele-wheel, POP & history \$57,500. 2) 1969 Fathom Grn cpe, grn lea., 427/390, 4-sp., AC, PS, PW, tilt-tele, all smog eqp, P02 covers, Redlines, POP \$42,500. 3) 1999 Pewter cpe, red int, 6-sp., heads-up, mag wheels, active handing, tilt-tele, twilight sent, Corsa exh, new Michelin Pilots, 27k, one owner, \$22,500. 4) four-post lift w/ many accessories; you remove it, \$750. Ron Barr #35704 704.841.1475.

WANTED

1119001 voltage regulator for '57 Corvette dated L56 or A,B,C,D-57. (864)710-7448 Gary Jaynes #3503

MISCELLANEOUS

Hagerty Collector Car Insurance

Protect your collector car with the very best protection available. Contact Bob Turner 34259 at Rick Hamby Agency 828-228-8768 Bt7169@yahoo.com

Business Minutes..... continued from p.12

John Pirkle

Dick Whittington and Janet Kennedy provided an update on John Pirkle's condition. He is in the hospital seriously ill with pulmonary fibrosis.

NCRS Website

There are links to photos from the 2011 National Convention at Novi on the website. Prints of any photo can be purchased.

No further business was conducted and the meeting was adjourned.

Carol McIntyre

Secretary – NCRS Carolinas Chapter

Corvette Parts Absolute Auction

Over 6,000 unique parts at auction

Friday, Nov. 18 and Saturday, Nov. 19, 2011, 10:00 A. M.

Preview Thursday, Nov. 17, 1:00-5:00 p. m.

190 Industrial Park Rd., Columbus NC

Mr. Charlie Brown is devoting his time and efforts to other business ventures and has commissioned Whittington Auction & Appraisal LLC to sell at **ABSOLUTE AUCTION** a very large assortment of Corvette parts and accessories. Parts from 1953 to 1990--assorted engines, transmissions, doors, convertible top frames, differentials, moldings, bumpers, lamps, headlamp assemblies, headlamp doors, gauge clusters, interior trim, seats, suspension pieces, grilles, glove box doors, three 1963 coupe roof panels, 1968-75 hardtops, half shafts, springs, latch mechanisms, door glass, emblems, hoods, and many more parts too numerous to list. Also for sale are the stack racks and storage bins parts are in. Bring your trucks and trailers, everything must go and will at some price.

Parts are sold as is, where is. Whittington Auction & Appraisal, Llc, offers no warranties, either express or implied, on any vehicle in this auction. Auctioneer will have the final say in any dispute.

Sales in this auction are subject to all applicable NC sales taxes. Dealers must show tax exemption.

BUYER'S PREMIUM: A 10% buyer's premium will be added to each purchase. If you bid \$100.00 at checkout you will be charged \$110.00. Payment due at the close of auction.

PAYMENT: Due at the end of the auction. Payment accepted by Visa, Master Card, and check, IF accompanied by bank letter of credit

Unless otherwise arranged, all purchases must be removed from premises by 5:00 p.m., Sunday. Items left will be considered abandoned and will be disposed of by owner or auctioneer at buyer's expense

Day-of-sale phone number 336.469.6967

Announcements made day of sale supersede printed material.

Not Responsible for Accidents **ALL SALES FINAL**

Dick Whittington. CAI, MPPA NCAL 8424

Whittington Auction & Appraisal Llc

Office: 288 Oakwoods Ln Wilkesboro NC 28697

336.838.8243 fax 336.232.1478 whittingtonauction.com

Please check our website regularly for updates on this auction.

More pictures and descriptions will added as soon as possible.

Auctionzip # 9741





MEMBERSHIP REGISTRATION FORM

- Your Membership Includes:**
- Local Technical Knowledge
 - Name Badge (*high quality magnetic backed*)
 - Quarterly Newsletter
 - Tech Sessions
 - Judging Schools
 - Road tours
 - Social Events

You must be an active member of the NCRS, Inc. to qualify for chapter membership. Please include your NCRS number where indicated on this form.

www.ncrcsCarolinaschapter.org

YOUR INFORMATION

Name _____ NCRS # _____
 Address _____
 City _____ State _____ Zip _____
 Home Phone _____ Work Phone _____
 Email Address _____ Birthday (m/d) _____
 YOUR SPOUSE/SIGNIFICANT OTHER
 Name _____
 Email Address _____ Birthday (m/d) _____

CHILDREN (*living in household*)

Name	M/F	Birthday (m/d/y)	Name	M/F	Birthday (m/d/y)

CORVETTE INFORMATION

Year	Model	Color

WOULD YOU BE WILLING TO ASSIST WITH ANY OF THE FOLLOWING?

- Judging
 Tabulating
 Membership
 Newsletter
 Events
 Other

If "Other" please specify, _____

PLEASE DESCRIBE ANY TALENTS OR ABILITIES THAT YOU MAY CONTRIBUTE TO THE SUCCESS OF OUR CHAPTER.

CHAPTER DUES: \$15 per family – payable upon application and renewed each January 31st.
Please make checks payable to: **Mall check with Membership Registration Form to:**
 Carolinas Chapter NCRS Sandi Aue, 610 Dorado Circle, High Point, NC 27265

I hereby state that I am a member in good standing of NCRS, Inc. and that I agree to abide by the NCRS and Carolinas Chapter Bylaws.

Signature: _____ Date: _____

Please direct any questions to: Chairperson Brian McIntyre – 704.785.4194 or bamcintyre@chapter.net

Enter additional information on the back of this form.

Financial Statement

Income

Carolinas Women's Auxiliary	1150.50
Chapter dues	789.21
Raleigh chapter meet	468.00
Gray Court judging school	180.00
Hendrick judging meet	350.00
Monroe judging meet	740.00
National Conv. hosting income	1500.00
West Jefferson judging meet	1060.00

Total Income 7259.71

Expense

Chapter picnic	60.00
CWA banner	53.38
Flowers	144.50
Gray Court expense	210.00
Judging materials /expenses	447.77
Membership	354.12
Monroe judging meet	56.11
Nametags	1191.02
Newsletter logo artwork	475.00
Newsletter	184.16
Postage	31.00
Raleigh judging	417.29
West Jefferson meet	698.22

Total Expenses 4322.57

Net Ordinary Income 2937.14

Cash balance 9868.68

Louis Kolb, Treasurer



Christmas Party

Saturday, December 10

1:00 to 4:00 p.m.

at the home of

Pete & Mary Mihaltian

3428 Wynington Drive

Charlotte NC 28226

I-485, take Exit 64A, NC 51N for appx. 2 mi

Left onto Carmel Road approx. 3 miles

Right onto Mooreland Drive (@ Royden gate houses) .2 mi.

Left onto Wynington Drive .1 mi. to #3428

(1st house on left)

The Redline Times
256 Oakwoods Lane
Wilkesboro NC 28697-7418

